

WOOD I-JOIST INSTALLATION TO WOOD

Sloped I-Joists

Use hangers with sloped seals whenever the slope exceeds the following: 1/2:12 for seat bearing lengths of 2 1/2 inches or less; 3/8:12 for bearing lengths between 2 1/2 inches and 3 1/2 inches; and 1/4:12 for bearing lengths in excess of 3 1/2 inches.

Multiple I-Joists

Fasten together multiple plies of wood I-joists, in accordance with the manufacturer's installation guidelines, such that the joists act as a single unit.

Rotation on I-Joists

It may be necessary to install straps, blocking or sheathing to restrain torsional rotation of a supporting wood I-joist when using top mount I-joist hangers.

Fasteners

Install only the specified nails. The flanges of wood I-joists may split if larger diameter nails or longer nails are installed. Do not install nails larger than 16 penny common (0.162 inch diameter) into the web stiffeners in the wood I-joist.

Backer Blocks

Pattern the nails used to install backer blocks or web stiffeners in wood I-joists to avoid splitting the block. The nail pattern should be sufficiently spaced and avoid the same grain line, particularly with solid sawn backer blocks. Backer blocks must be installed on the wood I-joists acting as the header, or supporting member. Install in accordance with the I-joist manufacturer's installation guidelines with the backer blocks seated against the bottom flange of a supporting header when using the face mount hangers, and against the top flange if using top mount hangers. The nails installed to hangers mounted to an I-joist header must penetrate through the web and into the backer block on the opposite side.

CORRECT SLANT NAIL INSTALLATION:

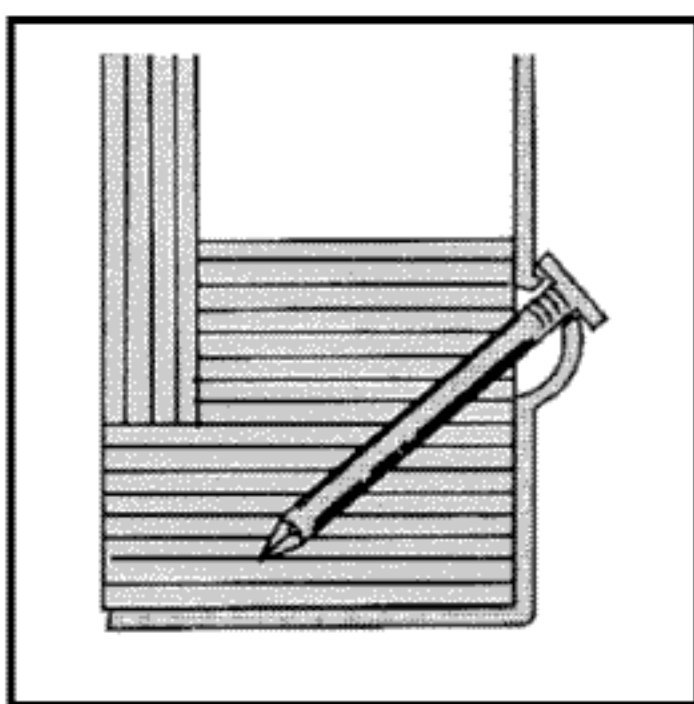

Always secure wood I-joist using 10d x 1-1/2" nail driven at a 45° angle and firmly seated.

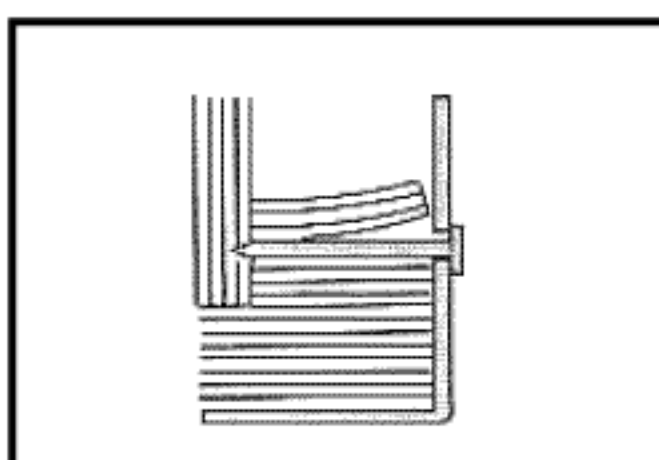

COMMON NAILING ERRORS

Wrong Angle:
When a nail is driven into the bottom flange of the wood I-joist parallel to the glue lines, separation of veneers can occur which substantially reduces the design loads of the connection.

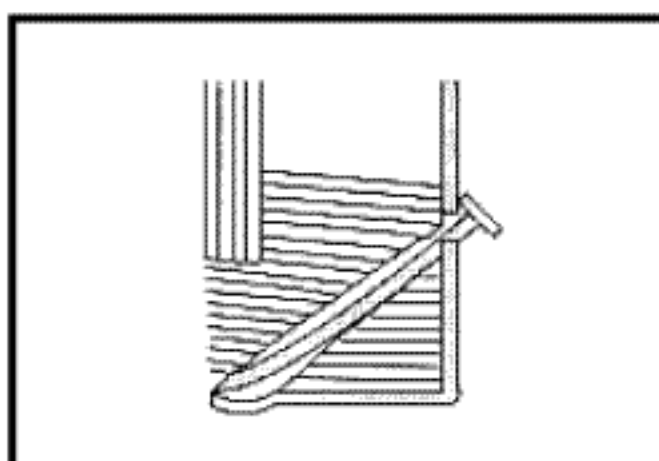

Nail too Long:
When using nails longer than USP Lumber Connectors recommended nails, splitting of the bottom flange can occur and also raise the wood I-joist off the seat. This can result in uneven surfaces and squeaky floors, along with reduced allowable loads.

Top Flange Hangers:

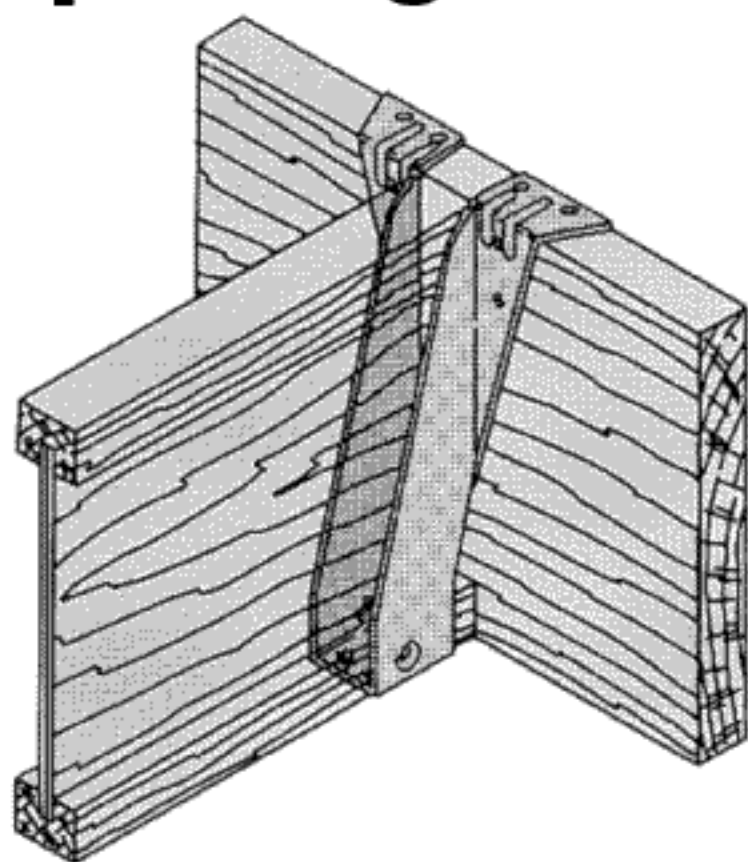

Flush Framing

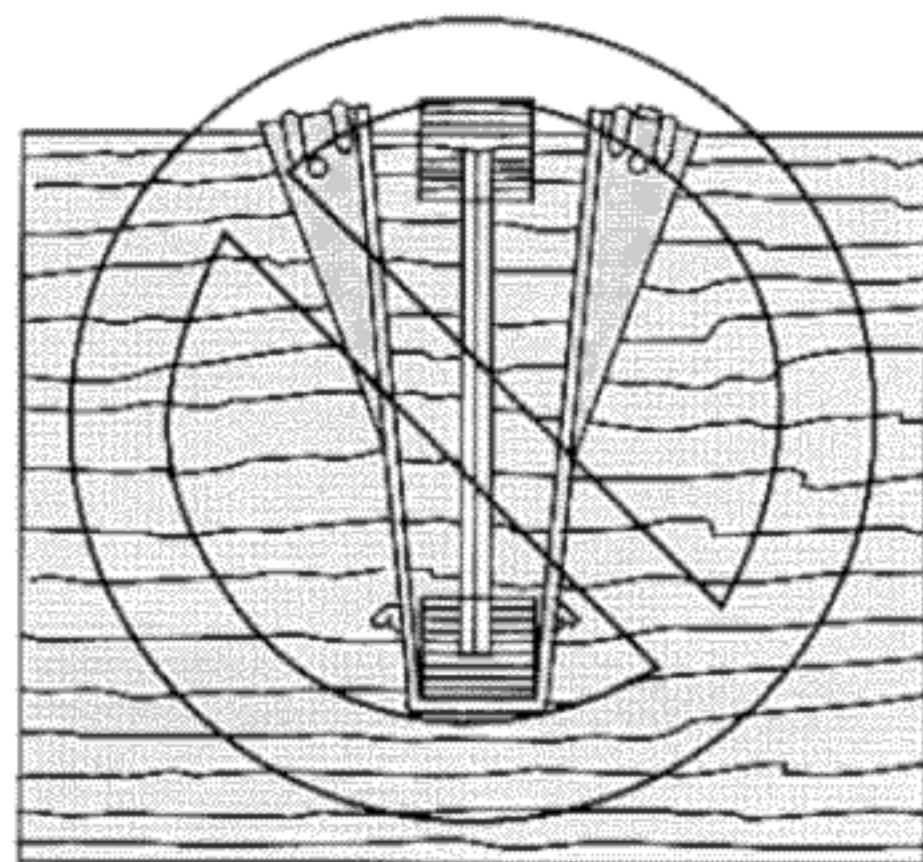

Hanger Over-Spread

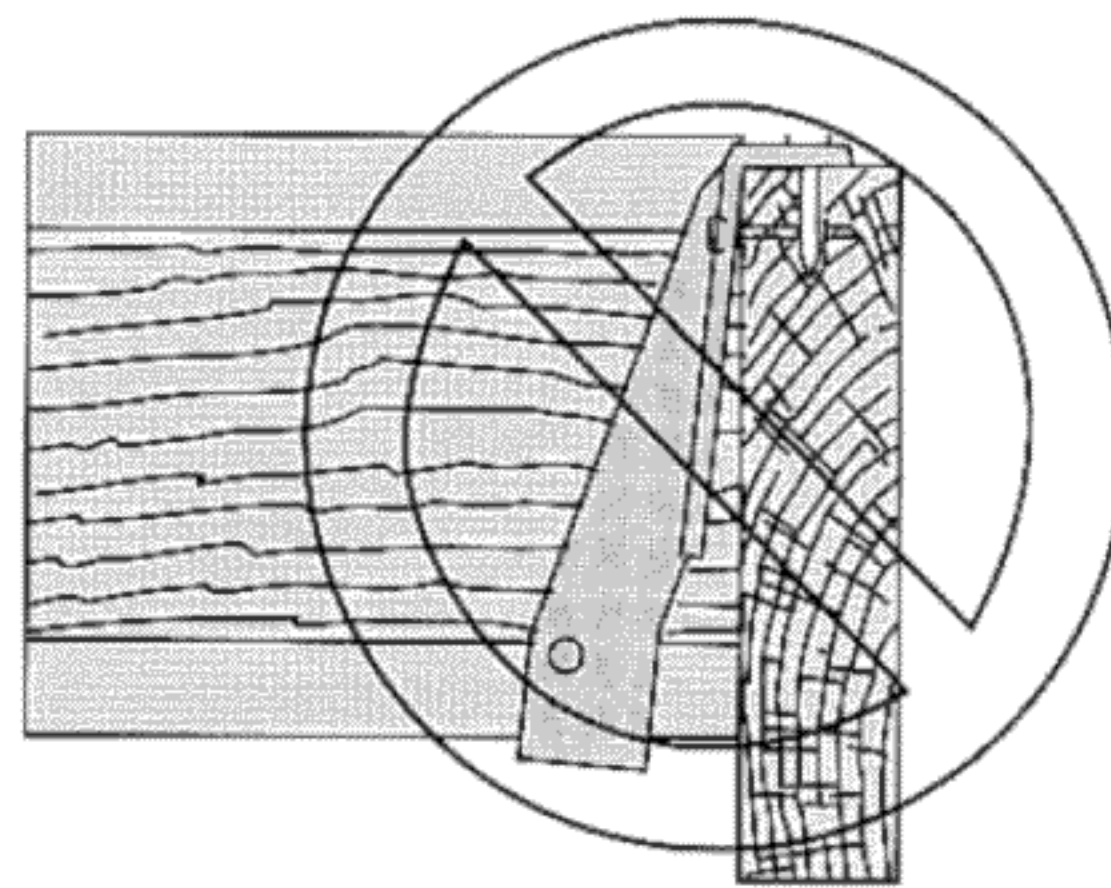

Hanger Not Plumb

The thickness of the metal and nail heads on top mount hangers must be evaluated for the effect on subsequent sheathing. Ensure the top mount hanger is installed such that the flanges of the hanger are not "over-spread" which tends to elevate the supported I-joist, causing uneven floor surfaces and squeaking. Similarly, ensure the hanger is installed plumb such that the face flanges of the hanger are mounted firmly against the wide-face surface of the header.

Support Height and Lateral Stability:

Without Web Stiffeners:

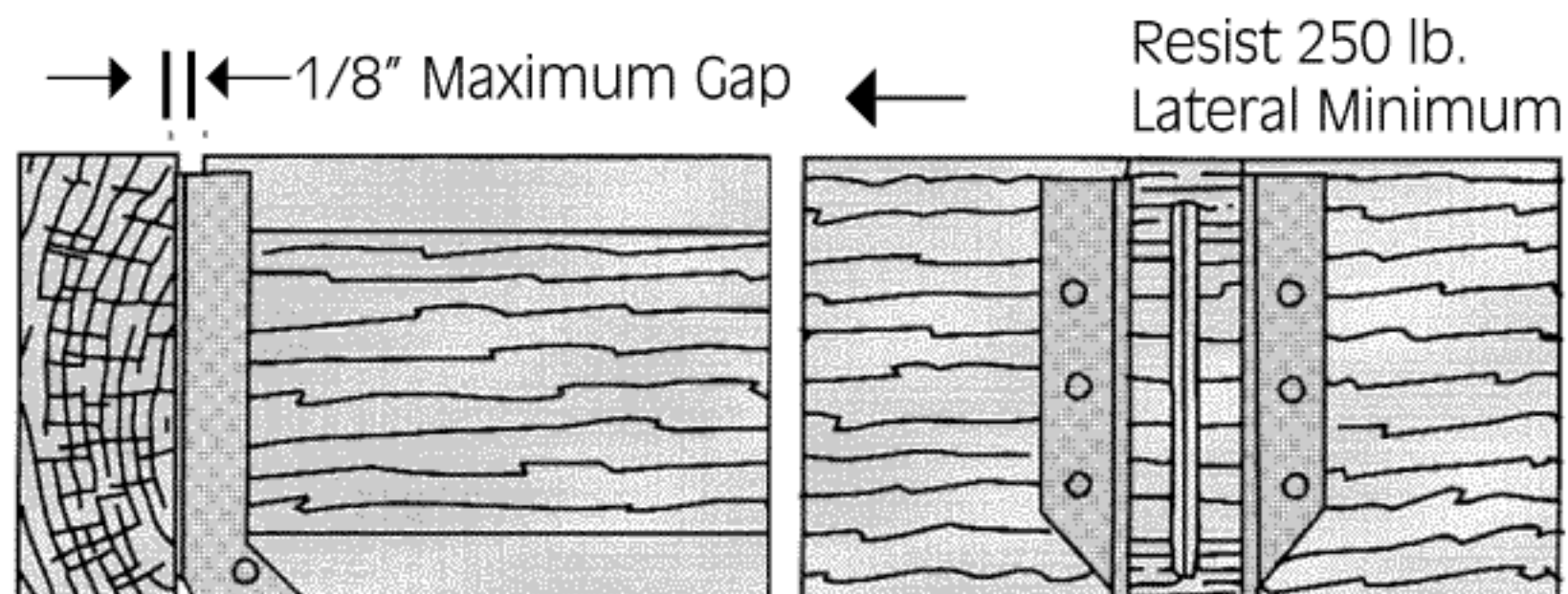

Hangers without web stiffeners must support I-joist top flange and provide minimum 250-pound lateral resistance with no more than 1/8" horizontal deflection.

With Web Stiffeners or Solid Members:

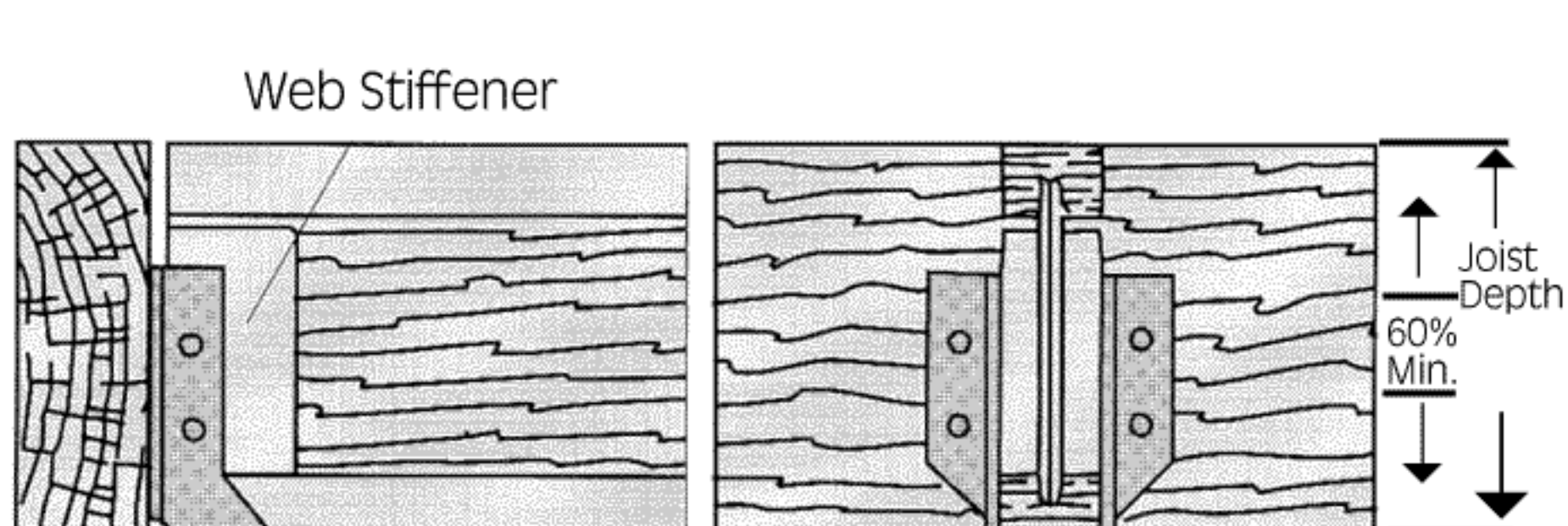

Hangers for joists with web stiffeners must support a minimum of 60% of joist depth.